

ABATO® *Motoren*

Innovation in Power Generation®

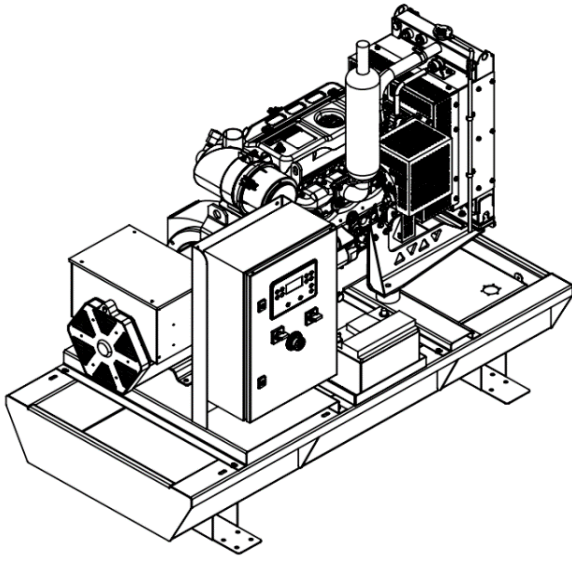

AB23-OPEN

Dimensions L x W x H	1725 x 838 x 1150 mm
Weight	800 kg

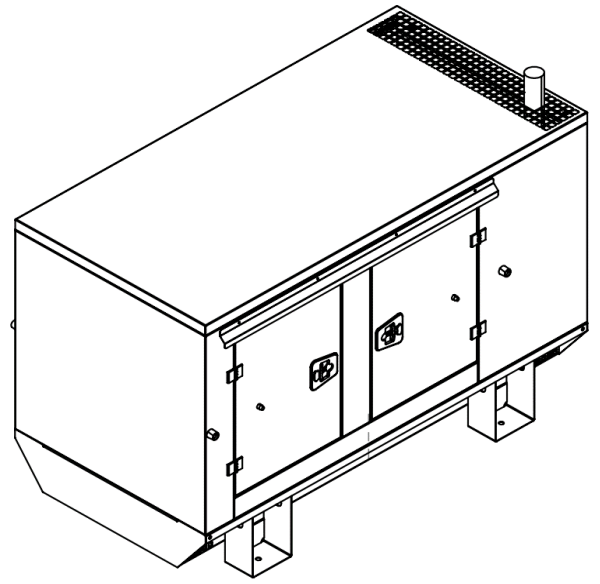

AB23-CANOPY

Dimensions L x W x H	2006 x 1000 x 1270 mm
Weight	801 kg

General information

Genset power PRP	23 kVA
Genset power ESP	25 kVA

Engine

Fuel	Diesel
Fuel tank capacity	100 L
Autonomy with 100% load	16,4 h
Engine speed	1500 rpm

Engine power (PRP)	18 kW
Rated current	33 A

Alternator

Voltage	400 V
Frequency	50 Hz
Rated power factor	0,8
Efficiency	86,5%

Prime Power (PRP)

Prime Power is the maximum power available for unlimited hours of usage in a variable load application. The average load factor should not exceed 70% of the engine's PRP power rating during any 24 hour period. An overload capability of 10% is available, however, this is limited to 1 hour within every 12 hour period.

Emergency Standby Power (ESP)

Emergency Standby Power is the maximum power available for a varying load for the duration of a main power network failure. The average load factor over 24 hours of operation should not exceed 70% of the engine's ESP power rating. Typical operational hours of the engine is 200 hours per year, with a maximum usage of 500 hours per year. This includes an annual maximum of 25 hours per year at the ESP power rating. No overload capability is allowed. The engine is not to be used for sustained utility paralleling applications.

ABATO® *Motoren*

Innovation in Power Generation®

Engine specifications

General information

Engine manufacturer	Baudouin
Engine model	4M06G25/5
Engine speed	1500 rpm
N° of Cylinders / Valves	4 / 8
Cylinders arrangement	In line
Bore x Stroke	89 x 92 mm
Displacement	2,3 L
Thermodynamic Cycle	Diesel 4 stroke
Compression ratio	17.5 : 1
Injection System	Direct
Fuel System	Mechanical Pump
Aspiration	Natural

Noise

Diesel engine noise	106 dB(A)
---------------------	-----------

Lubrication system

Oil capacity Low / High	7.1 / 9.5 L
Oil pressure under normal conditions	2 - 5 Bar
Max. oil temp	115 °C
Oil fuel consumption ratio	≤ 0.4 %
Total system capacity including filters	11,5 L

Electrical system

Electrical system voltage	12 V
Starter power	3 kW
Dynamo charger current	35 A

Air intake

Air intake temperature rise	≤ 5 °C
Air intake restriction clean filter	≤ 35 mbar
Air intake restriction dirty filter	≤ 60 mbar
Recommended air flow PRP	1,4 m ³ /min
Recommended air flow ESP	1,4 m ³ /min
Min. diameter of intake pipe	50 mm

Exhaust system

Max. exhaust back pressure	80 mBar
Max. exhaust temp before turbocharger	700 °C
Max. exhaust temp after turbocharger	N/A
Exhaust flow @ PRP	4,9 m ³ /min
Exhaust flow @ ESP	5,3 m ³ /min
Min. diameter of exhaust pipe	50 mm

Cooling system

Max. ambient temp up to	50 °C
Radiator type	Mechanical
Fan type	Belt driven pusher
Coolant capacity of radiator and pipes	4 L
Thermostat opening temp	72 °C
Thermostat full open temp	82 °C
Coolant capacity of the engine	5 L
Cooling fan airflow	63 m ³ /min

Aftercooling system

Aftercooler system type	N/A
Max. intake temp @ 25°C ambient	N/A
Max. diff intake / ambient temp	N/A
Max. pressure drop aftercooler	N/A

Fuel system

Governor	Electronic
Max. pressure at fuel inlet	1,3 Bar
Max. fuel inlet temp	50 °C
Fuel supply flow	40 L/h

Fuel consumption

Consumption at 100% ESP	7,1 L/h
Consumption at 100% PRP	6,1 L/h
Consumption at 75% PRP	4,5 L/h
Consumption at 50% PRP	3,2 L/h
Consumption at 25% PRP	2,0 L/h
Fuel consumption tolerance	± 3%

*All ratings are based on operating conditions under ISO 8528-1, ISO 3046, DIN6271 Performance tolerance of ±5%.

ABATO® *Motoren*

Innovation in Power Generation®

Alternator specifications

General information

Alternator manufacturer	XINGNUO or eq.
Alternator model	XN184EF or eq.
Voltage	400 V
Frequency	50 Hz
Rated power factor	0,8
Technology	Brushless, AVR
Voltage measurement	3-phase
Efficiency	86,5%

Cooling

Cooling air	0.071 m ³ /sec
Temp rise cont. H	125/40 °C

Protection and distortion

Insulation system	H
Protection	IP23
Telephone interference	THF <2%
Waveform distortion without load	< 1.5%
Waveform distortion with a linear load	< 5.0%

Internal assembly

Maximum overspeed	2250 Rev/Min
Stator winding	Double layer concentric
Winding pitch	2/3
Winding leads	12
Bearing amount	1
Stator wdg. Resistance per phase at 22°C	0.25 Ohms
Rotor wdg. Resistance at 22°C	0.74 Ohms

Alternator highlights

Low telephone interference (THF) as defined by IEC 60034-1
 High efficiency and motor startup capability
 Rigid assembly, effectively reduces the vibration during running
 All rotors are dynamically balanced to conform with BS6861
 Non-maintenance sealed-for-life ball bearing
 Suitable for environment with 95% relative humidity

*Used alternator meets the requirements of BS5000, VDE0530, UTE5100, NEMA MGt-22, CEMA, IEC34-1, CSAC22.2-100 and AS1359

ComAp IntelliLite AMF 25

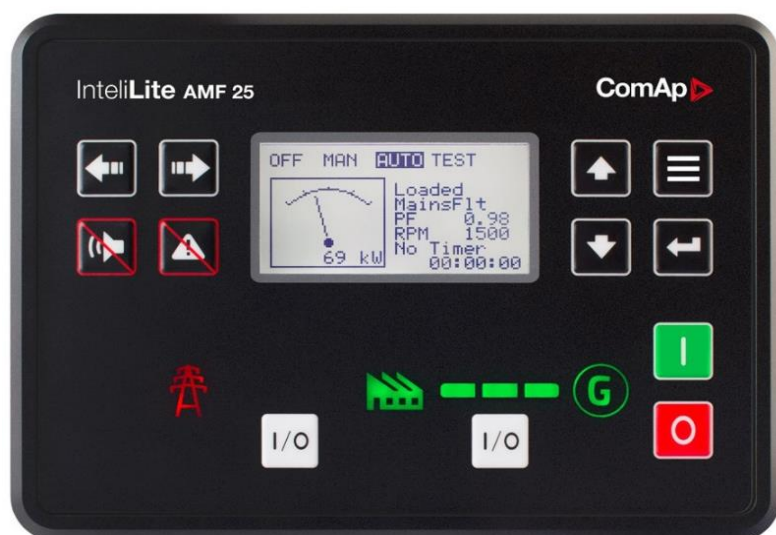

The following features are included in the used model:

- Standby and Prime power applications
- Flexible event based history with up to 350 events
- 3 Phase generator current measurement
- Generator and Mains phase voltage measurement
- Active/reactive power measurement
- Active and reactive energy counter
- Battery charging alternator circuit connection
- Comprehensive gen-set protections
- CAN and USB on board
- Internet access using Ethernet, GPRS or 4G module
- Support for Modbus and SNMP protocols
- Cloud-based monitoring and control via WebSupervisor
- Active SMS or e-mails (module required)
- Geofencing and tracking via WebSupervisor
- 2x 10 A binary outputs for cranking and fuel solenoid
- Option for up to 16 additional binary inputs/outputs
- Operating temperature -20 + 70°C
- IP65 operator interface protection